

FLUID POWER DATA

HYDRAULIC CYLINDER DATA



HYDRAULIC CYLINDER FORCES AT VARIOUS PRESSURES

Cyl. Bore Dia.	Piston Rod Dia	Cyl. Working Action	Work Area Sq. In.	Hydraulic Pressure (psig)					Cyl. Bore Dia.	Piston Rod Dia	Cyl. Working Action	Work Area Sq. In.	Hydraulic Pressure (psig)					
				500	1000	1500	2000	3000					500	1000	1500	2000	3000	
1.5"		Push	1.77	884	1768	2652	3536	5304	6"		Push	28.27	14137	28274	42411	56548	84822	
	D .62	P	1.46	730	1460	2190	2920	4380		K 2.5	P	23.36	11682	23364	35046	46728	70092	
	F 1.0	L	.98	490	980	1470	1960	2940		L 3.00	U	21.20	10600	21200	31800	42400	63600	
2"		Push	3.14	1570	3140	4710	6280	9420		M 3.50	L	18.65	9325	18650	27975	37300	55950	
	F 1.0	P	2.36	1178	2356	3534	4712	7068		N 4.00	L	15.70	7854	15708	23562	31416	47124	
	G 1.38	L	1.66	828	1656	2484	3312	4968			Push	38.48	19242	38484	57726	76968	115452	
2.5"		Push	4.91	2454	4908	7362	9816	14724		7"		P	31.41	15708	31416	47124	62832	94248
	F 1.0	L	4.13	2062	4124	6186	8248	12372			M 3.50	U	28.86	14430	28860	43290	57720	86580
	G 1.38	L	3.43	1710	3420	5130	6840	10260			N 4.00	L	25.92	12960	25920	38880	51840	77760
3.25"		Push	8.29	4148	8296	12444	16592	24888			P 4.5	L	22.58	11290	22580	33870	45160	67740
	G 1.38	P	6.81	3405	6810	10215	13620	20430	R 5.00		L	18.85	9425	18850	28275	37700	56550	
	H 1.75	L	5.88	2940	5880	8820	11760	17640			Push	50.26	25132	50264	75396	100528	150792	
4"		Push	12.57	6283	12566	18849	25135	37698	8"			P	40.64	20322	40644	60966	81288	121932
	H 1.75	U	10.15	5080	10160	15240	20320	30480			N 4.00	L	37.70	18850	37700	56550	75400	113100
	J 2.0	L	9.43	4710	9420	14130	18840	28260			P 4.50	L	34.36	17180	34360	51540	68720	103080
5"		Push	19.63	9817	19634	29451	39268	58902			R 5.00	L	30.63	15315	30630	45945	61260	91890
	J 2.0	P	16.50	8246	16492	24738	32984	49476		S 5.50	L	26.50	13253	26506	39759	53012	79518	
	K 2.5	L	14.73	7360	14720	22080	29440	44160			Push	78.54	39270	78540	117810	157080	235620	
5"		Push	19.63	9817	19634	29451	39268	58902		10"		P	62.64	31320	62640	93960	125280	187920
	L 3.00	U	12.57	6280	12560	18840	25120	37680			R 5.00	L	58.90	29450	58900	88350	117800	176700
	M 3.50	L	10.02	5006	10012	15018	20024	30036			S 5.50	L	54.78	27390	54780	82170	109560	164340
											T 7.00	L	40.06	20030	40060	60090	80120	120180

Fluid Power Data

HYDRAULIC CYLINDER SPEED VS GPM REQUIRED

BORE	1	2	3	4	5	6	7	8	9	10	20	30	40	50	60	GPM PER IN/SEC
1.50	.46	.92	1.4	1.8	2.3	2.8	3.2	3.7	4.1	4.6	9.2	14	18	23	28	.460
2.00	.82	1.6	2.5	3.3	4.1	4.9	5.7	6.5	7.4	8.2	16	25	33	41	49	.817
2.50	1.3	2.6	3.8	5.1	6.4	7.7	9.0	10	12	13	26	38	51	64	77	1.28
3.25	2.2	4.3	6.5	8.6	11	13	15	17	19	22	43	65	86	108	130	2.16
4.00	3.3	6.5	9.8	13	16	20	23	26	29	33	65	98	131	164	196	3.27
5.00	5.1	10	15	20	26	31	36	41	46	51	102	153	204	256	307	5.11
6.00	7.4	15	22	29	37	44	52	59	66	74	147	221	294	368	442	7.36
7.00	10	20	30	40	50	60	70	80	90	100	200	300	400	500	599	9.99
8.00	13	26	39	52	66	79	92	105	118	131	262	393	524	655	786	13.1
10.00	20	41	61	82	102	122	143	163	184	204	408	612	816	1020	1224	20.4
12.00	29	59	88	118	147	176	206	235	265	294	588	882	1176	1470	1764	29.4
14.00	40	80	120	160	200	240	280	320	360	400	800	1200	1600	2000	2400	40.0

HYDRAULIC CYLINDER STOP TUBE DATA: MOUNTING CONSIDERATIONS

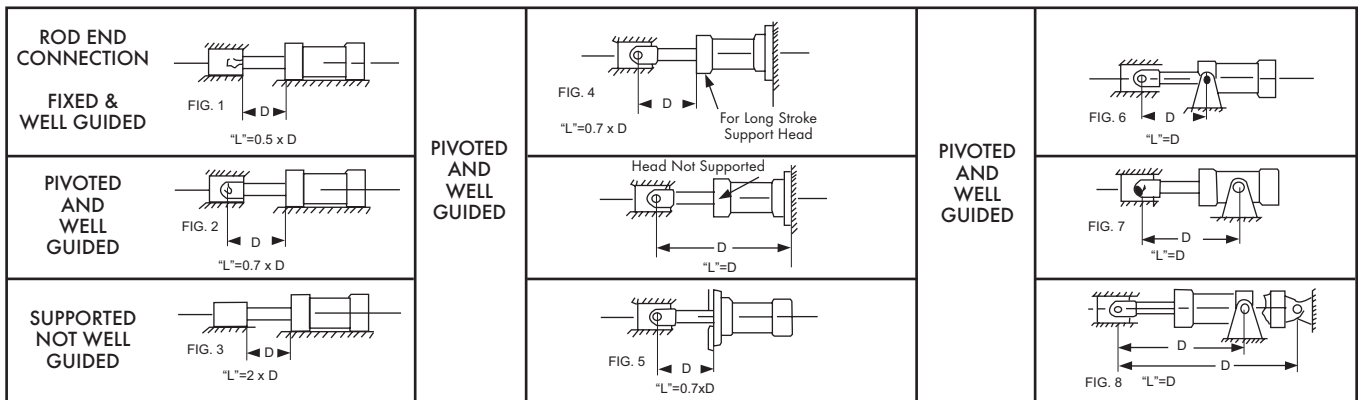

FLUID POWER DATA

FORMULAS



HYDRAULIC CYLINDER STOP TUBE DATA CONT'D

Long stroke cylinders can be subjected to a buckling action and excessive bearing wear due to the weight of the exposed rod. To reduce wear a stop tube is recommended.

We recommend all cylinders cushioned and non-cushioned supplied with the double piston stop tube construction- especially when working horizontally.

The rod diameter has to be capable of withstanding any compressive force developed by the cylinder working against the load. A piston rod diameter with adequate column strength to handle the compressive force of the application can be selected from the convenient pre-calculated chart below.

To use this chart find the force value, developed by the application, in the left column. Next select the figure which resembles your application and then multiply "D" times the factor given in that figure. Finally, opposite the corresponding force value, find the value of "L" which is equal to, or greater than, the figure derived from factoring "D". Directly above is the rod diameter which is capable of withstanding the forces developed in the application.

EXAMPLE: Cylinder Bore = 4.00" Operating PSI = 750
 Force Value 9428 lbs.
 Application - Resembles Fig. 2 - Foot Lug Mtg.
 Stroke = 40"
 "L" = 0.7 x 40; L = 28"
 Correct Rod Diameter = 1.38"

SEE MOUNTING
 CONSIDERATIONS
 BOTTOM PAGE 144:
 "L" DEFINED FOR
 VARIOUS MOUNTING
 METHODS

The total force is 9428 lbs., and the value of "L" is 28 inches in this application. The smallest diameter rod capable of handling this situation is 1.38 inches.

If a stop tube is required for the application, be sure to include the stop tube length when determining the length of "D".

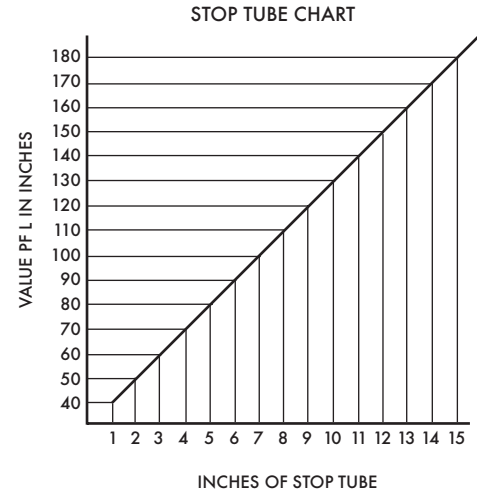

STROKE LIMITATION DATA

FORCE IN POUNDS	PISTON ROD DIAMETER												
	.62	1.00	1.38	1.75	2.00	2.50	3.00	3.50	4.00	4.50	5.00	5.50	7.00
100	66												
200	47												
400	33	85											
600	27	70	132										
800	24	60	114	184									
1000	21	54	102	165	215								
1300	18	47	90	145	188								
1700	16	41	78	127	165	258							
2100	14	37	71	114	149	232							
2500	13	34	65	104	136	213	304						
3000	12	31	58	95	124	192	280	381					
4000	10	27	51	83	108	162	242	330	430				
5000	9	24	46	74	96	150	217	295	385				
6000	8	22	42	67	89	137	198	269	352	443			
8000	7	19	36	58	76	119	172	233	305	384	475		
10000		17	32	52	68	106	153	209	273	344	426	514	
12000		15	29	48	62	97	139	190	249	314	328	468	761
16000		13	26	42	54	84	121	165	215	272	316	407	659
20000			23	38	48	75	109	148	193	243	301	365	590
30000			18	31	39	61	89	120	153	198	245	297	481
40000				27	34	53	77	104	136	172	213	257	417
50000				23	31	48	69	93	122	153	190	230	373
60000				21	28	44	63	85	111	140	174	210	340
80000					24	38	54	74	96	122	143	192	295
100000						34	48	66	86	109	132	163	264
120000						31	44	60	79	100	121	142	240
140000							41	56	73	92	112	135	223
160000							38	52	63	86	105	129	209
200000								47	61	77	93	115	187
250000								42	54	69	84	103	167
300000													152
350000													141
400000													131
500000													118

ROD CLEVIS

*Caution: Accessory load rating may be lower than maximum force available from the cylinder

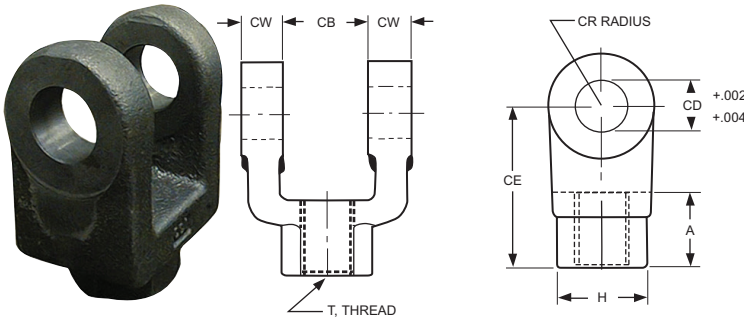

P/N	ROD CODE/DIA	CD PIN/DIA	T THREADS	CE	CB	CW	CR	A	H	*LBS CAPACITY
BDC-05	D/0.62	0.50	.44-20	1.50	.75	.50	.62	.75	1.00	5360
BDC-07	F/1.0	0.75	.75-16	2.38	1.25	.62	.88	1.12	1.25	14000
BDC-10	G/1.38	1.0	1.00-14	3.12	1.50	.75	1.12	1.62	1.75	22500
BDC-13	H/1.75	1.375	1.25-12	4.12	2.00	1.00	1.62	2.00	2.00	41250
BDC-17	J/2.0	1.75	1.50-12	4.50	2.50	1.25	2.00	2.25	2.75	57000
BDC-20	K/2.5	2.00	1.88-12	5.50	2.50	1.25	2.25	3.00	3.00	75000
BDC-25	L/3.0	2.50	2.25-12	6.50	3.00	1.50	2.88	3.50	3.50	112500
BDC-30	M/3.5	3.00	2.50-12	6.75	3.00	1.50	3.12	3.50	3.88	135000
BDC-35	P/4.5	3.50	3.25-12	8.50	4.00	2.00	3.88	4.50	5.00	210000
BDC-40	S/5.5	4.00	4.00-12	10.0	4.50	2.25	4.38	5.50	6.19	270000

ROD EYE

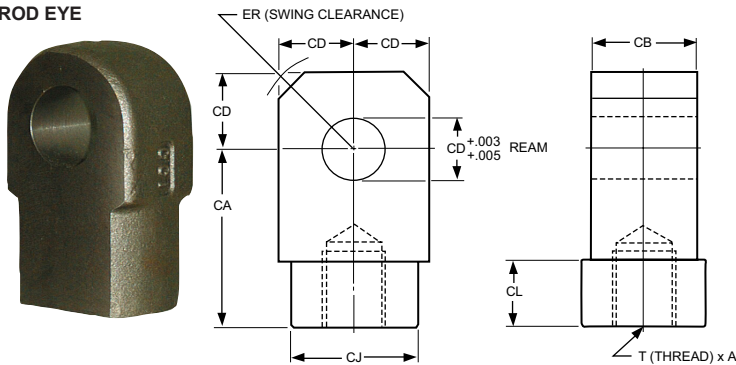

P/N	ROD CODE/DIA	CD PIN/DIA	T THREADS	CA	CB	CL	CR	A	CJ DIA	*LBS CAPACITY
BDE-05	D/0.62	0.50	.44-20	1.50	.75	-	.75	.75	-	5360
BDE-07	F/1.0	0.75	.75-16	2.06	1.25	-	1.12	1.12	-	12500
BDE-10	G/1.38	1.0	1.00-14	2.81	1.50	-	1.44	1.62	-	20250
BDE-13	H/1.75	1.375	1.25-12	3.44	2.00	-	2.00	2.00	-	37000
BDE-17	J/2.0	1.75	1.50-12	4.00	2.50	-	2.50	2.25	-	59000
BDE-20	K/2.5	2.00	1.88-12	5.00	2.50	2.50	2.88	3.00	3.25	67500
BDE-25	L/3.0	2.50	2.25-12	5.81	3.00	2.81	3.56	3.50	4.00	101250
BDE-30	M/3.5	3.00	2.50-12	6.12	3.00	2.50	4.25	3.50	5.00	121500
BDE-35	P/4.5	3.50	3.25-12	7.62	4.00	3.50	5.00	4.50	6.12	189000
BDE-40	S/5.5	4.00	4.00-12	9.12	4.50	4.50	5.75	5.50	7.00	243000

PIN

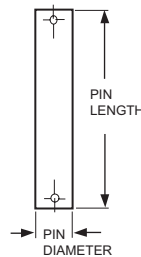
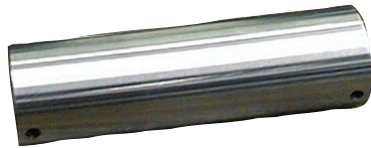

P/N	LENGTH	DIAMETER	*LBS CAPACITY
BDP-054	2.28	.50	6125
BDP-074	3.09	.75	13800
BDP-104	3.60	1.00	24500
BDP-134	4.66	1.37	46500
BDP-174	5.66	1.75	75150
BDP-204	5.72	2.00	98150
BDP-254	6.94	2.50	153400
BDP-304	7.19	3.00	220900
BDP-354	9.31	3.50	300650
BDP-404	10.31	4.00	307850

EYE BRACKET



P/N	CD	2H SERIES BORE DIA	3L SERIES BORE DIA	AA	CB	DD	DE	E	F	FL	LR	M	MR	*LBS CAPACITY
BDEB-05	.500	1.50	1.50, 2.00, 2.50	2.30	.75	.44	.56	2.50	.38	1.12	.62	.50	.62	2500
BDEB-07	.750	2.00, 2.50	3.25, 4.00, 5.00	3.60	1.25	.56	.88	3.50	.62	1.88	.88	.75	.88	6300
BDEB-10	1.000	3.25	6.00	4.60	1.50	.69	1.38	4.50	.75	2.25	1.25	1.00	1.25	10000
BDEB-13	1.375	4.00		5.40	2.00	.69	1.75	5.00	.88	3.00	1.75	1.38	1.75	19250
BDEB-17	1.750	5.00		7.00	2.50	.94	2.25	6.50	.88	3.12	2.12	1.75	2.12	21200
BDEB-20	2.000	6.00		8.10	2.50	1.06	2.56	7.50	1.00	3.50	2.38	2.00	2.38	24500
BDEB-25	2.500	7.00		9.30	3.00	1.19	3.12	8.50	1.00	4.00	2.94	2.50	2.94	25000
BDEB-30	3.000	8.00		10.60	3.00	1.31	3.25	9.50	1.00	4.25	3.19	2.75	3.19	22500
BDEB-35	3.500	10.00		13.60	4.00	1.81	-	12.62	1.69	7.25	3.62	3.50	3.62	58500
BDEB-40	4.000	12.00		16.19	4.50	2.06	-	14.88	1.94	7.75	4.12	4.00	4.12	73250

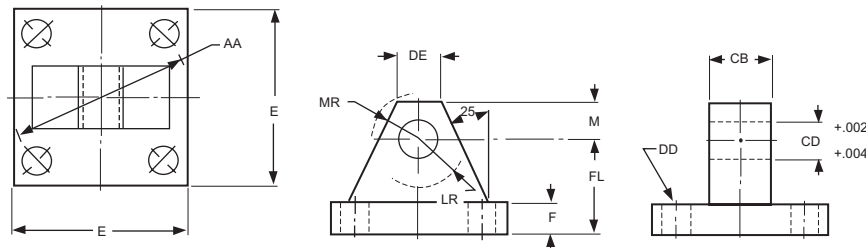

FLUID POWER DATA

CYLINDER MOUNTING ACCESSORIES



Self-Aligning Rod End Coupling permits fast, easy assembly, disassembly, installation and servicing. Precision-machined, two-piece steel construction provides close radial alignment between piston rod end and machine member.

Allowing for radial movement increases seal and bearing life within the cylinder by eliminating much of the side load. High-tensile alloy steel, socket head cap screws and all-steel, socket head cap screws and all-steel construction are designed to take full cylinder load with a factor of safety.

The Self-Aligning Rod End Coupling is used in conjunction with the RC rod end.

A Weld Plate is an added accessory or use with the Self-Aligning Rod End Coupling. It eliminates lay-out, drilling and tapping each hole to match the coupling on your machine. The hole in the center of the Weld Plate is accurately drilled for a locating pin for fast, close positioning to the machine prior to welding.

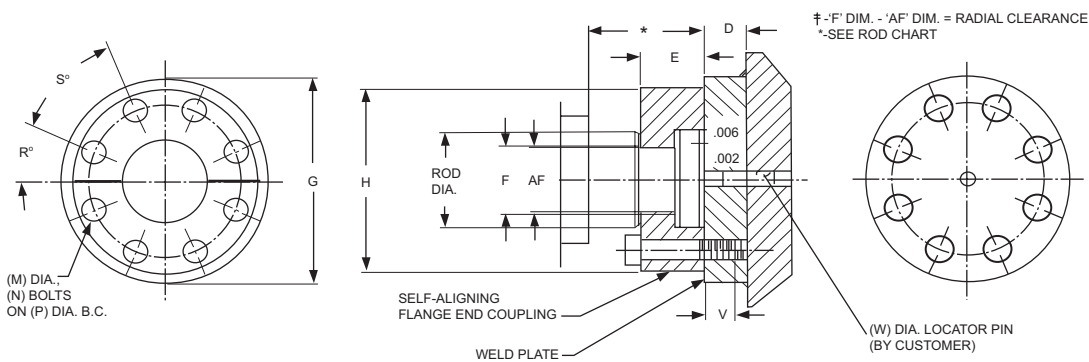
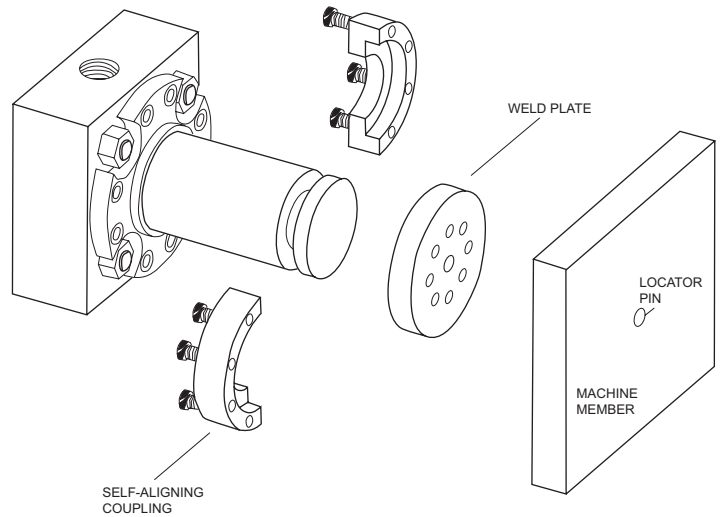

COUPLING NO.	ROD DIA. MM	AF †	E	F †	H	M	N	P	R	S	V	WELD PLATE NO.	D	G	W PIN DIA.	BOLT TORQ. FT. LB.
CP - 062	.62	.375	.44	.406	1.50	10-24	4	1.12	45	90	.438	CP - 062	.500	2.00	.25	5
CP - 100	1.00	.688	.62	.750	2.00	.250-20	6	1.50	30	60	.375	CP - 100	.500	2.50	.25	13
CP - 138	1.38	.875	.69	.938	2.50	.312-18	6	2.00	30	60	.562	CP - 138	.625	3.00	.25	25
CP - 175	1.75	1.12	.88	1.19	3.00	.375-16	8	2.38	22.5	45	.625	CP - 175	.750	3.50	.25	45
CP - 200	2.00	1.38	1.25	1.44	3.50	.375-16	12	2.69	15	30	.750	CP - 200	.875	4.00	.38	45
CP - 250	2.50	1.75	1.38	1.88	4.25	.500-13	8	3.44	22.5	45	.875	CP - 250	1.00	5.00	.38	80
CP - 300	3.00	2.25	1.88	2.38	5.00	.500-13	12	4.00	15	30	.875	CP - 300	1.00	5.50	.38	80
CP - 350	3.50	2.50	2.00	2.62	5.88	.625-11	12	4.69	15	30	1.00	CP - 350	1.12	6.50	.38	200
CP - 400	4.00	3.00	2.00	3.12	6.38	.625-11	12	5.19	15	30	1.00	CP - 400	1.12	7.00	.38	200
CP - 450	4.50	3.50	2.38	3.62	6.88	.750-10	8	5.69	22.5	45	1.12	CP - 450	1.25	7.50	.38	350
CP - 500	5.00	3.88	2.50	4.00	7.38	.625-11	12	6.19	15	30	1.00	CP - 500	1.38	8.00	.38	200
CP - 550	5.50	4.38	3.12	4.50	8.25	.750-10	12	6.88	15	30	1.38	CP - 550	1.50	9.00	.38	350

NOTE: FOR LARGER COUPLING SIZES, CONSULT FACTORY

ROD STYLE	ROD CODE	ROD DIA. INCHES	AC	AD	AE	AF DIA.	B DIA. -.001 -.003
RC - 062	D	.625	1.12	.625	.250	.375	1.12
RC - 100	F	1.00	1.62	.938	.375	.688	1.50
RC - 138	G	1.38	2.25	1.06	.375	.875	2.00
RC - 175	H	1.75	2.75	1.31	.500	1.12	2.38
RC - 200	J	2.00	3.12	1.69	.625	1.38	2.62
RC - 250	K	2.50	4.00	1.94	.750	1.75	3.12
RC - 300	L	3.00	4.50	2.44	.875	2.25	3.75
RC - 350	M	3.50	4.50	2.69	1.00	2.50	4.25
RC - 400	N	4.00	5.00	2.69	1.00	3.00	4.75
RC - 450	P	4.50	5.50	3.19	1.50	3.50	5.25
RC - 500	R	5.00	6.00	3.19	1.50	3.88	5.75
RC - 550	S	5.50	6.50	3.94	1.88	4.38	6.25

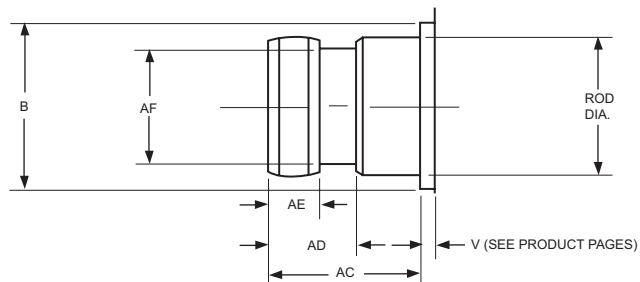

Fluid Power Data