

## General Features

### Standard Material Specifications

- High Strength Cast Iron
- Hard Chrome Plated Interchangeable Spools
- Steel Spring Caps
- Aluminum Lever Caps
- NBR Seals

### Standard Features

- 3/4" 1 to 7 Spool Monoblock Valve
- Adjustable Relief Valve (500-5000 psi)
- Housed Knuckle Joint
- Parallel Circuit
- Double Action
- Load Hold Check Valve

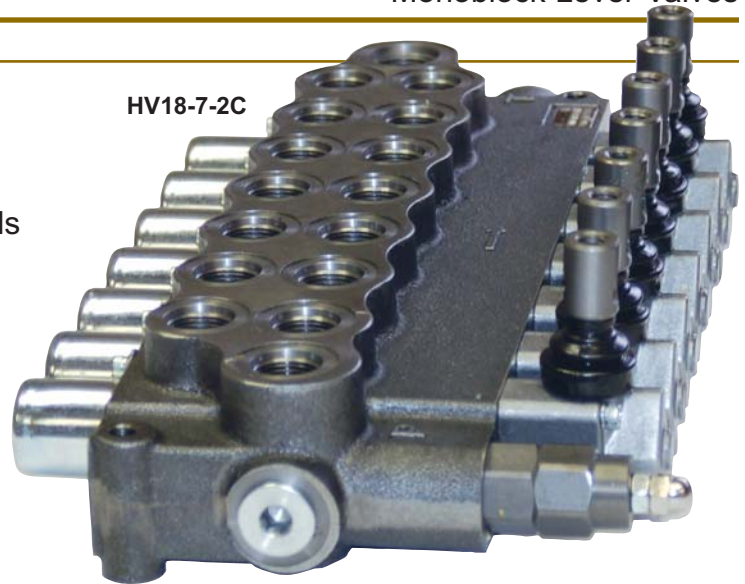

HV18 Series is a 18.5 gpm (70 lpm) monoblock valve available up to seven spools. Having the capacity of 18.5 gpm HV18 Series valves are used in larger machines and bigger pumps. Typical applications are: hydraulic presses, garbage and tipping trucks, hydraulic platforms, front-end loaders etc.

## General Specifications

### Standard Working Conditions

- Flow Rate.....18.5 gpm (70 lpm)
- Maximum Operating Pressure.....5000 psi (350 Bar)
- Maximum Back Pressure.....435 psi (30 Bar)
- Recommended Fluid Temperature Range.....-4° to 176°F (-20° to 80°C)
- Ambient Temperature Range.....-31° to 140°F (-35° to 60°C)
- Recommended Oil Viscosity Range..... 10 cSt to 75 cSt
- Internal Leakage (at 1450 psi (100 Bar); 32 cSt, 104°F (40°C)).....4 to 9 cc/ min
- Recommended Oil Filtering.....β 10 > 75
- Maximum Contamination Level.....Class 9 (NAS 1638)  
19/16 (ISO 4406)

### Technical Specifications

- Number of Spools.....1 - 7
- Weight.....Varies by number of spools selected (see following page)

### Dimensional Data

Units: mm (inches)

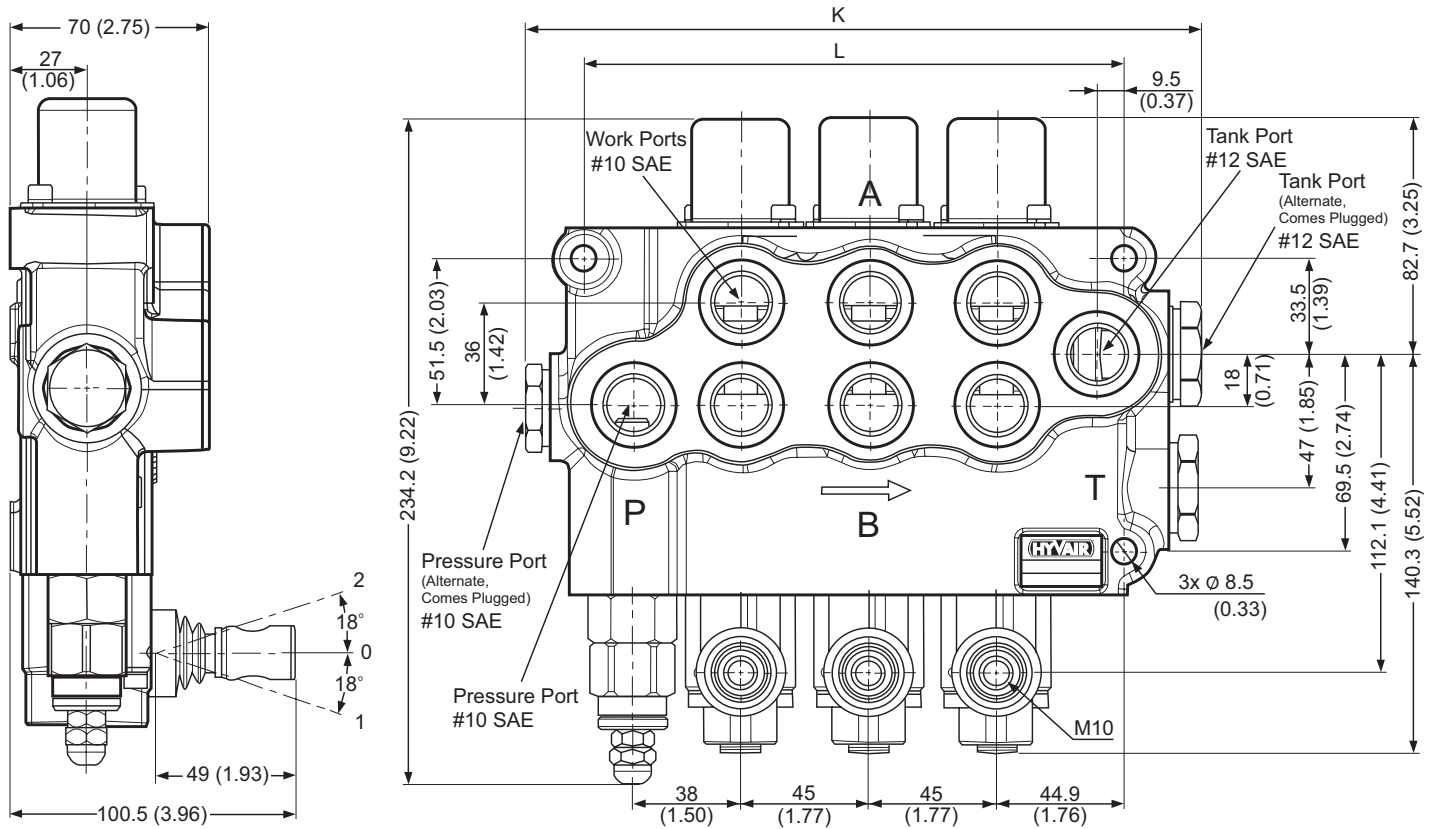

Type	L mm (inch)	K mm (inch)	Weight kg (lbs)
HV18 - 1	100 (3.94)	147.5 (5.81)	5.65 (12.4)
HV18 - 2	145 (5.71)	192.5 (7.58)	8.25 (18.2)
HV18 - 3	190 (7.48)	237.5 (9.35)	10.85 (23.9)
HV18 - 4	235 (9.25)	282.5 (11.12)	13.45 (29.6)
HV18 - 5	280 (11.02)	327.5 (12.89)	16.05 (35.3)
HV18 - 6	325 (12.80)	372.5 (14.67)	18.65 (41.0)
HV18 - 7	370 (14.57)	417.5 (16.44)	21.25 (46.5)

**Main Relief Valve**

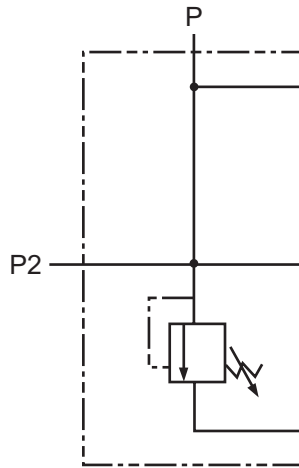
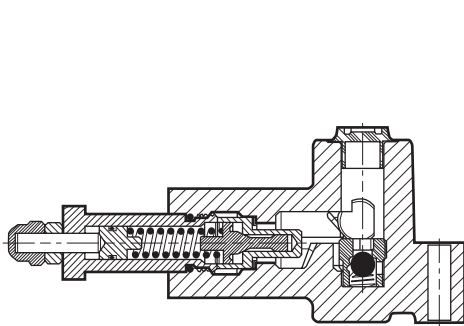

Inlet with Main Relief Valve

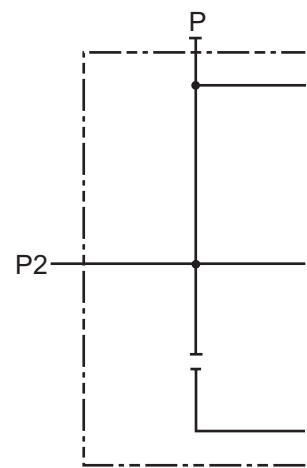

Inlet without Main Relief Valve

**Hydraulic Circuit**

**Parallel Circuit**

When the spool is operated, it intercepts the switch gallery by diverting the flow of oil to service port A or B. If two or more spools are actuated at the same time, the oil will power the service port that has the lower load by selecting the path with the least resistance; by throttling the spools, the flow of oil can be divided between two or more service ports.

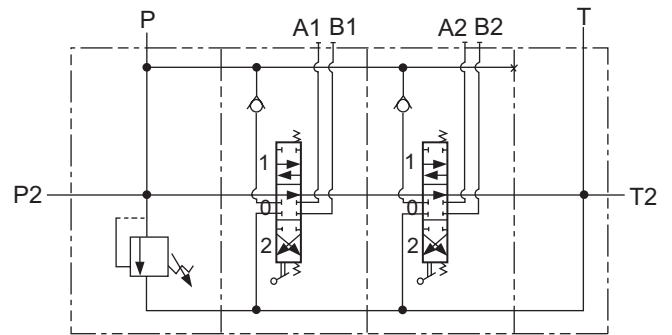

**Series Circuit**

When the spool is operated, it intercepts the switch gallery by diverting the flow of oil to service port A or B. The oil that flows back from the actuator is carried to the switch gallery thus making it available to the service ports downstream from the series section. The pressure drop downstream is added to the pressure drop of the section itself.

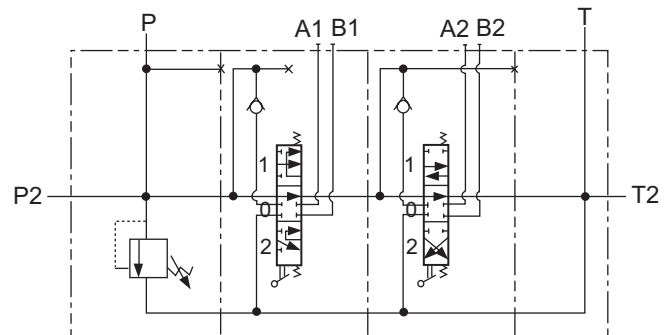

### Spool Control Position/ Pressure Drop Curves

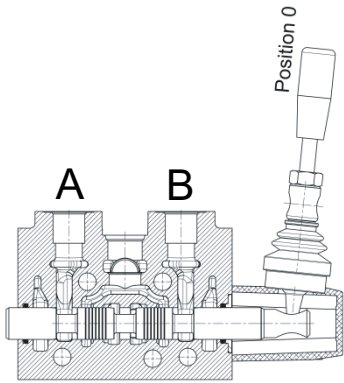

Spool-neutral position:  
**POSITION 0**

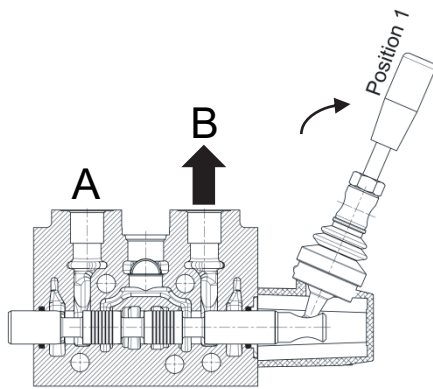
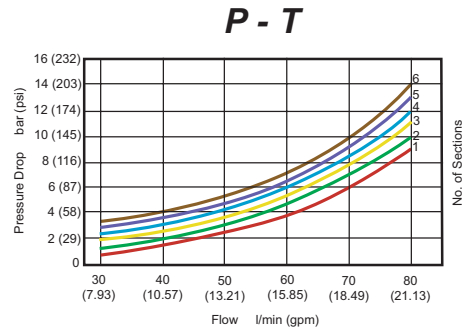

Spool-out position:  
**POSITION 1**

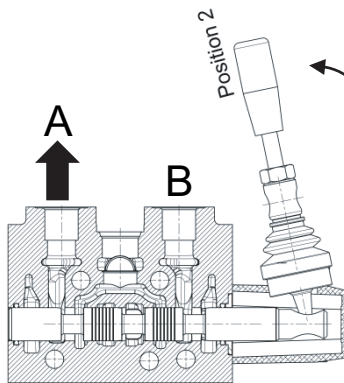
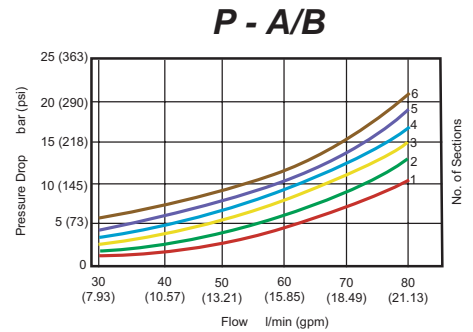

Spool-in position:  
**POSITION 2**

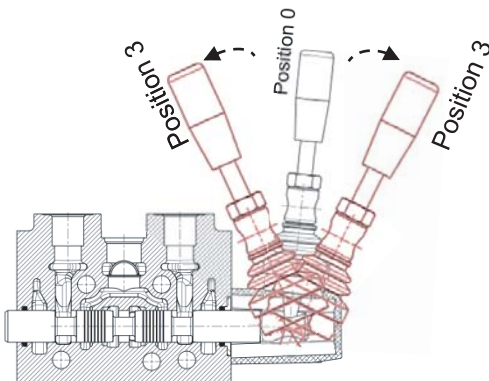

4 positions and 4th position  
can be spool-in or spool-out  
position optionally:  
**POSITION 3**

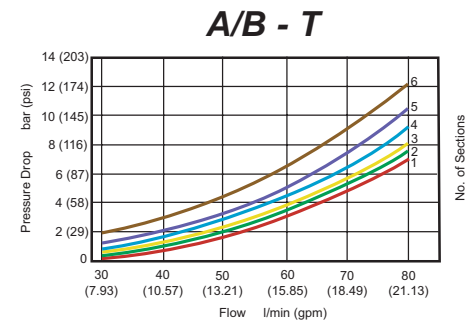

**Ordering Information**

**HV18 - 4 - 2 C**

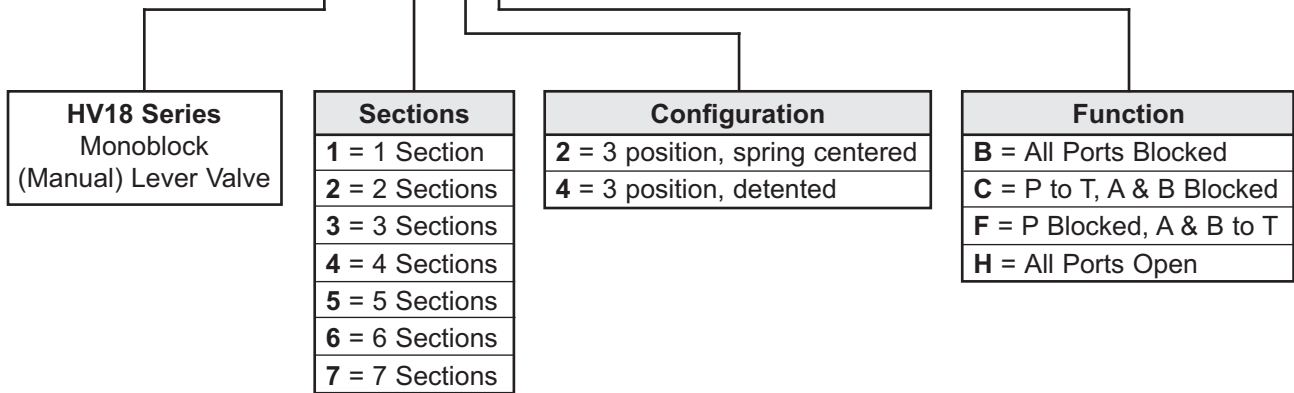

Options
HVHANDLE = Handle
HV18-DK = Detent Kit
HV18-PB = Power Beyond Sleeve
HV18-CCP = Closed Center Plug
HV18-IN-POR = Inlet Relief- Pilot Operated Relief



Units: mm (inches)

