

Mounting Bolt/O-Ring Information			
Bolt	Torque ft-lbs (Nm)	O-Ring (P,T,A,B)	O-Ring (X,Y)
(6) M20x80-10.9	95.8 (130)	42mm ID x 3mm CS	19mm ID x 3mm CS

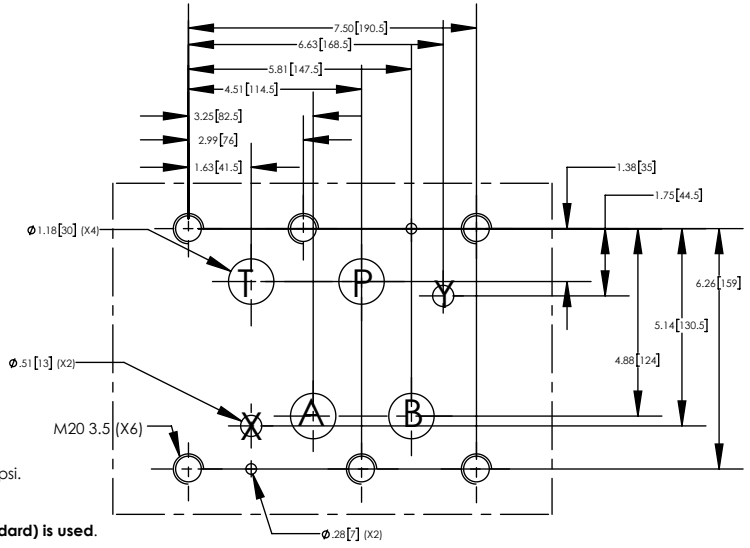

DETAIL FOR P/N:
D10S--**-35**
(D03S--**-35 Pilot Valve)**

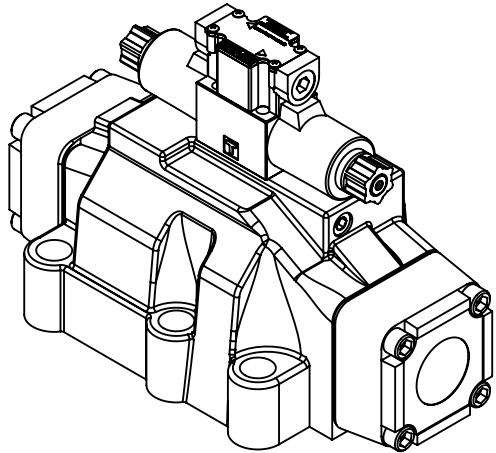
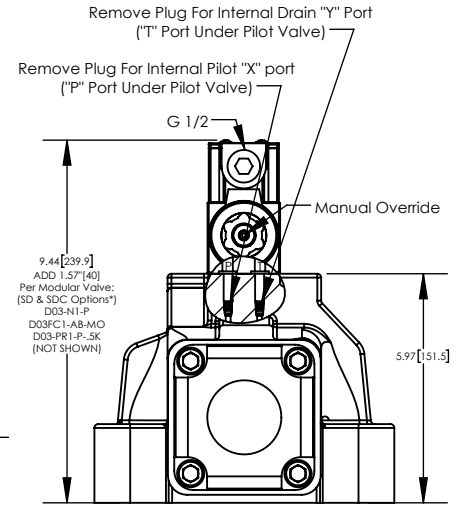
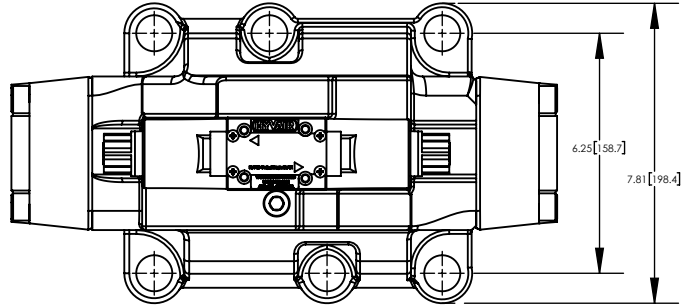
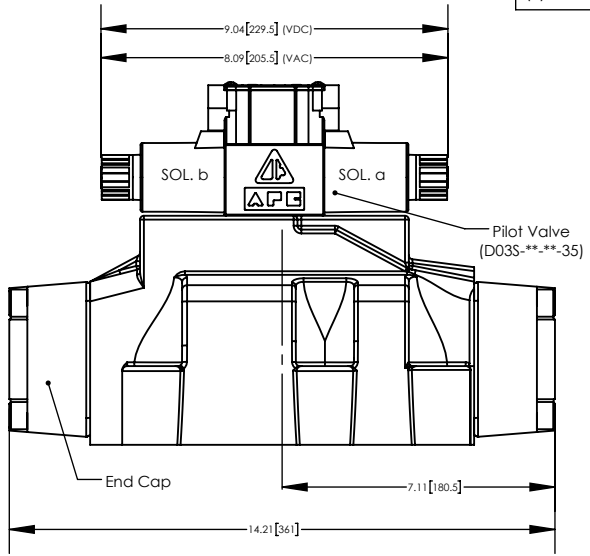

31341 Friendship Dr.
 Magnolia, TX 77355
 P: (281) 259-7768
 F: (281) 259-7249
 sales@hyvair.com

SCALE: 1:5 UNITS: INCH [mm]

*Pilot choke valve (SC/SDC), D03-FC1-AB-MO- meter out flow control, provides softer shifting.
 Also consider additionally using D03-PR1-P-.5K- pressure reducing valve if system is above 1,000 psi.
Options:
 "EP" suffix for External Pilot (x-port connection) "ED" suffix for External Drain (y-port connection)
At least one of these options must be used on C & H spools unless internal Pre Load Check (Standard) is used.